

**LUMEX**

**Avance-25**

**Avance-60**

**HYBRID METAL 3D PRINTER**



**LUMEX Avance-25 / LUMEX Avance-60**

# From Vision to Reality

**Matsuura** led the world in 2002 in the commercialization of the “Hybrid Metal 3D Printer”. Since then, our technological and competitive strengths have been enhanced significantly through version upgrades.

In 2016, the **LUMEX Avance-60** was introduced to meet the demands for large-size parts and high-speed operation.

In 2017, the technologies introduced for the **LUMEX Avance-60** have been applied to the **LUMEX Avance-25**, further enhancing our competitive strength.

The highly advanced fusion of laser technology and high-precision cutting technology enable revolutionary manufacturing.



Laser Sintering



Deep Rib Processing



Hollow Structures



Time Reduction



3D Free-Form Surface



Finish Machining



Milling



Porous Sintering



3D Meshes



Cost Reduction



Integrated Structures



Undercut Machining

## Revolution in Metal Processing

Metal laser sintering using a laser beam to melt metal powder and high-speed high-precision machining using end mills. These processes are repeated to produce the designed shape in one process on a single machine.

**Matsuura**'s hybrid technologies achieve machining accuracy and surface finish comparable to machining centers, surpassing the capability of conventional metal 3D printers.

## High-Speed Operation

The build speed is greatly increased by employing high-output laser, optimized galvano control / sintering conditions, improved powder distribution, etc. The latest specifications produce a maximum build speed of 16 cc/h\* with 500 W laser; 35 cc/h\* with 1 kW laser. The milling time is also greatly reduced through pre-milling powder suction and optimal path creation with the **LUMEX CAM** software. The reduction of processing time is achieved in both sintering and milling phases.

## Redefining the Manufacturing Processes

The **LUMEX** series manufactures parts at near net shape, 3D objects with complex interior structures and creates components with hollows, 3D meshes and free-form surfaces. In addition, deep ribs, impossible to machine with machining centers, can be produced without using EDMs.

This advanced technology is gaining attention not only in the die and mold industry but also in the aircraft and medical industries.

\*This is the result with Matsuura Maraging II. The actual performance may vary depending on the metal powder material, part shape and size.



[ Laser Output ]  
Standard 1kW  
Option 500W  
[ Spindle Speed ]  
45000  $\text{mm}^{-1}$

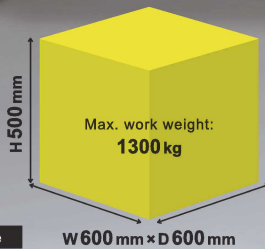

Max. work size



[ Laser Output ]  
Standard 500W  
Option 1kW  
[ Spindle Speed ]  
45000  $\text{mm}^{-1}$

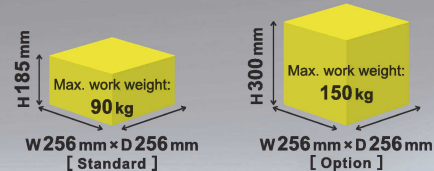

Max. work size



2002



2003



2004



2006

# LUMEX

[ Processes ]

## Hybrid AM Manufacture with metal laser processing and high-speed milling



### Powder Distribution

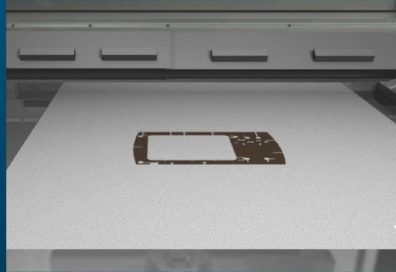

Processing table

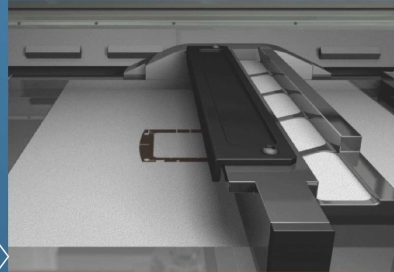

Powder blade

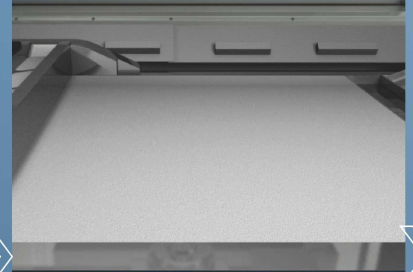

Metal powder

Repeated Laser Processing for 10 Layers

The **LUMEX** series repeats metal laser processing and high-speed, high-precision milling to form metal powder into shapes and makes deep ribs in a single process without EDMs. Dimensional accuracy and comparable to machining centers is achieved.

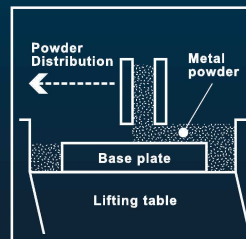

### 1. Powder Distribution

Metal powder is distributed\* on the base plate installed on the table.

With Matsuura Maraging II  
 \* 0.05-mm thick for 500 W laser  
 \* 0.1-mm thick for 1 kW laser

## LUMEX dedicated CAM software



### Laser Scan Paths

Automatic creation of laser scan paths by simply selecting a material parameter template for each material



Scanning cell order

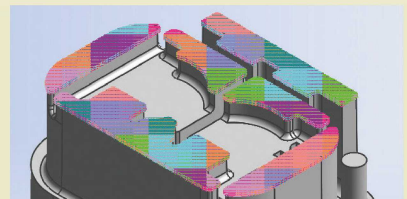

Scanning cell size, cell order, and direction can be customized.

### Milling Paths

Milling path creation from milling condition templates

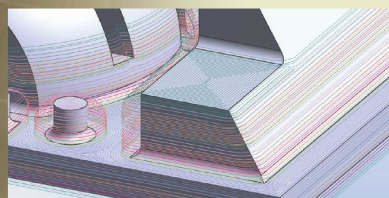

Path point / direction arrow display  
 Milling processes in different colors

**LUMEX CAM** is CAM software dedicated to the **LUMEX** metal 3D printer series. Metal laser scan and milling paths can be created with ease. The laser scan and milling path simulation function helps to check the created paths before start of processing.

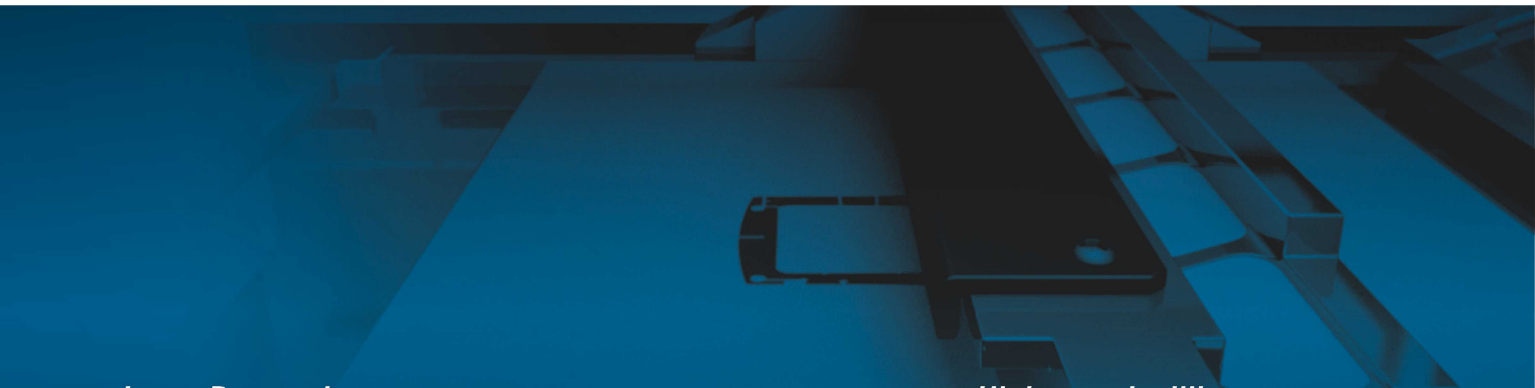

### Laser Processing

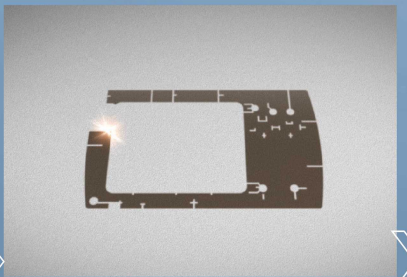

### High-speed milling

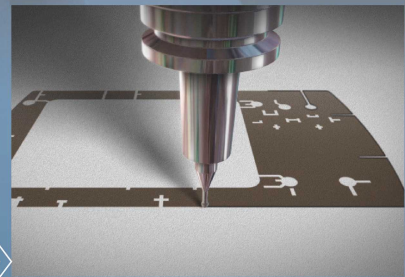

High-speed milling is performed per every 10 layers.

Repeated metal laser processing and high-speed milling

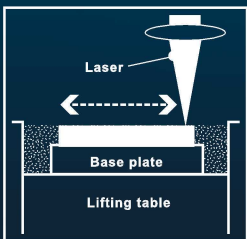

### 2. Laser Processing

Laser processing solidifies the powder layer on the processing table. When processing is finished, the processing table is lowered and metal powder for the next layer is distributed by the distribution unit. The laser then irradiates this powder to complete the next layer. The processes 1 and 2 are repeated 10 times and then milling starts.

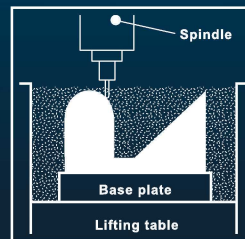

### 3. Milling

The outer surface of the built part is precision finished at a high speed with a ball endmill. Milling is performed when not after all layers have been completed but during build, after each preset number of layers. This hybrid, layer build process enables manufacture of parts with complicated structures.

## Processing techniques

### Back-Taper

Back-taper shaped parts can be produced. After sintering up to layer C, the  $\alpha$  area which is at a distance  $\beta$  can be finished.

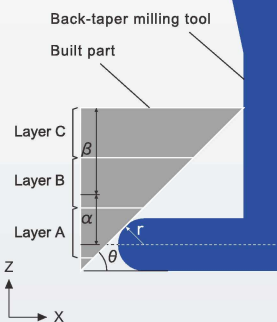
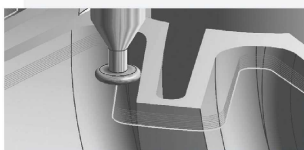

### Pre-Milling Powder Suction

By removing metal powder around the built part before starting milling, a faster milling speed and a large-diameter tool can be used to shorten the milling time. At the same time, surface finish is improved with less tool wear, enabling efficient manufacture.

\* Panasonic Corporation owns a patent regarding the "pre-milling powder suction function".

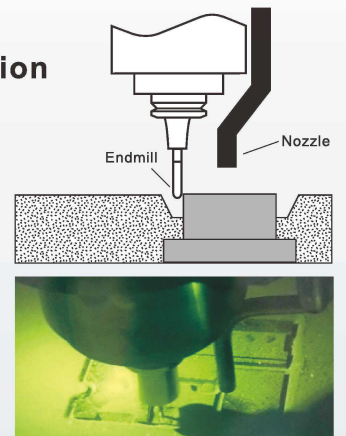

### Step Machining Process

[ Japanese Patent No. 4452692 ]

By repeating the process of "laser processing → semi-finishing → finishing", discoloration of the finish surface as well as steps which may occur between a milled layer and a laser processed layer due to heat shrinkage can be prevented. Such a function has been developed and given the name "Step Machining Process".

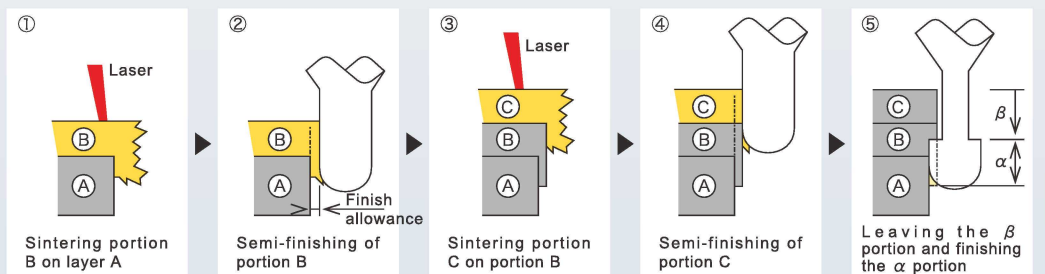

[(3) to (5)] are repeated.

## Manufacturing highly advanced molds in a single process.

Molds with complex internal cooling channels and porous structures are sintered with ease. Enables rapid production of high performance molds.

[ SAMPLE WORK ]  
Waterproof Connector

**LUMEX Avance-25**

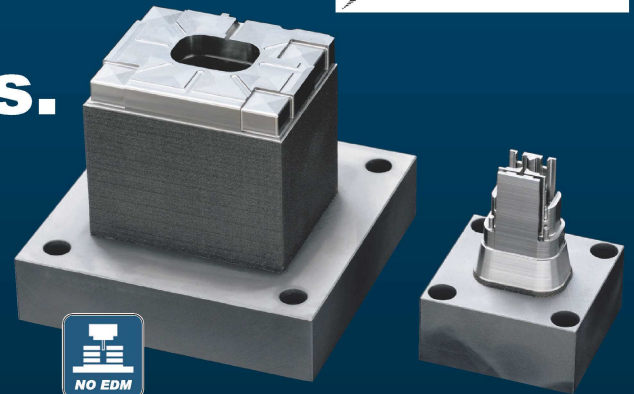

### Creating deep ribs by hybrid processing and without EDM

Deep ribs and thin ribs are created with high precision by the hybrid AM process. Mold manufacture without EDM is possible.

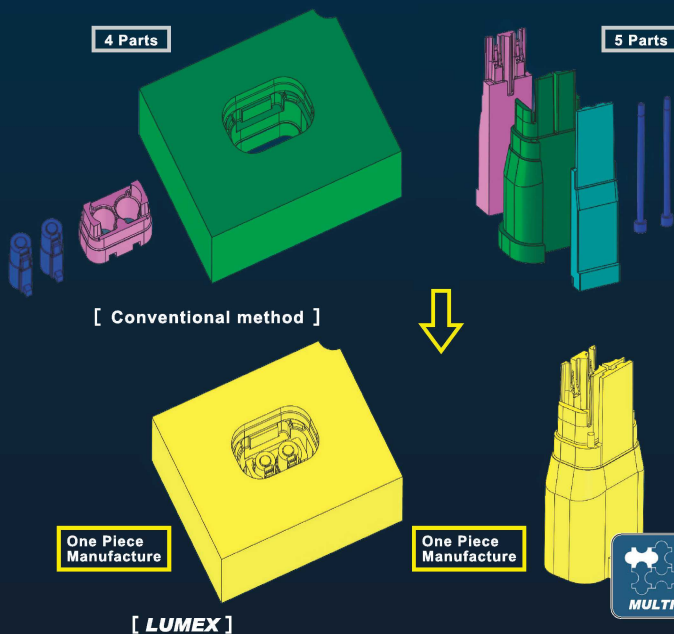

### Integrated one piece mold production

Even complicated molds can be manufactured in one piece, thus eliminating assembly and adjustment, and making it possible to produce molds with no dimensional errors that may be caused by conventional assembly processes.

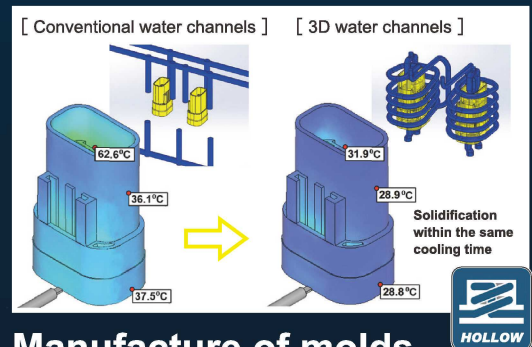

### Manufacture of molds with 3-dimensional cooling channels

Integrated cooling channels can be created internally on any component or mold. Compared to conventional post process cooling channels, these channels exhibit far superior and efficient cooling, contributing to a significant reduction in injection molding time.

Injection molding cycle time reduction by **33%**

### Porous structure for gas venting

Air permeability can be controlled freely by creating a porous structure, simply by adjusting the density of the built part. This achieves gas venting more effectively than any other machine. Users can expect the reduction of resin filling time, prevention of uneven filling, and elimination of gas burning.

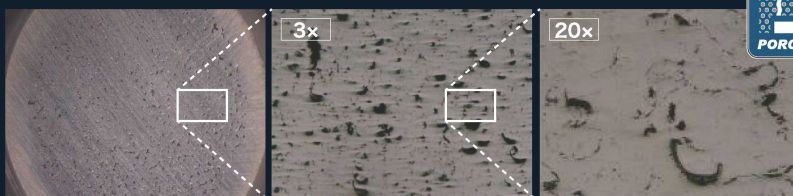



## Reduction in lead time from design to finish

The **LUMEX** series can produce molds in one piece and eliminates the need for EDM, assembly or adjustment. In addition, the time required for design and CAM processing can be shortened drastically. Even with deep-ribbed molds, the design time is reduced by approx. 53%, CAM time by 90%, and manufacture time by 83%. In total, a 50% reduction in mold production time is achieved compared with conventional methods.

[ Conventional method (machining center) ]

- Roughing
- Grinding
- MC machining
- Wire EDM, etc.
- Turning
- NC processing
- EDM
- Assembly
- Adjustment

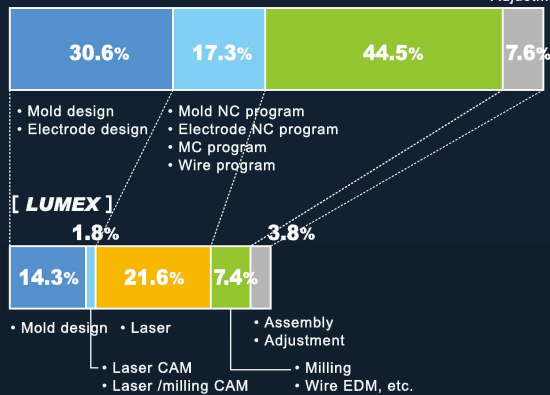

Designing: **53%** reduction  
 Data processing: **90%** reduction  
 Machining: **83%** reduction  
**TOTAL -50%**

## Application to lattice structures

The **LUMEX** series can be used to create molds with an internal lattice structure. This reduces the part volume and laser processing time. While maintaining the required strength, hollow portions and surface areas can be increased, improving cooling efficiency.

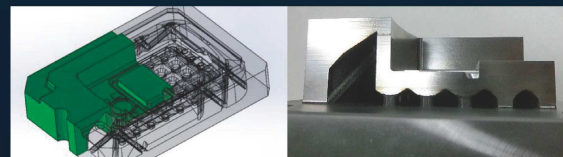

Cost reduction  
 Part volume: **32%** reduction  
 Laser processing time: **42%** reduction

Model design  
 by static rigidity analysis  
 to maintain strength

Increased hollow portions  
 and surface areas  
 for higher cooling efficiency

[ SAMPLE WORK ]

Digital camera casing



# LUMEX

[ Advantages in Part Manufacture ]

## High speed, large part size Internal lattice structures never before possible can be realized.

Significant contribution to innovative manufacturing of highly functional, value-added products, such as parts with complicated internal structures, hollow light-weight parts, large-size parts like engine blocks, etc.



[ SAMPLE WORK ]

### V8 Engine Block

**LUMEX Avance-60**

Size: W424×D317×H339 mm  
Material: Aluminum Si 10 Mg

Max. work weight:  
**1300 kg**

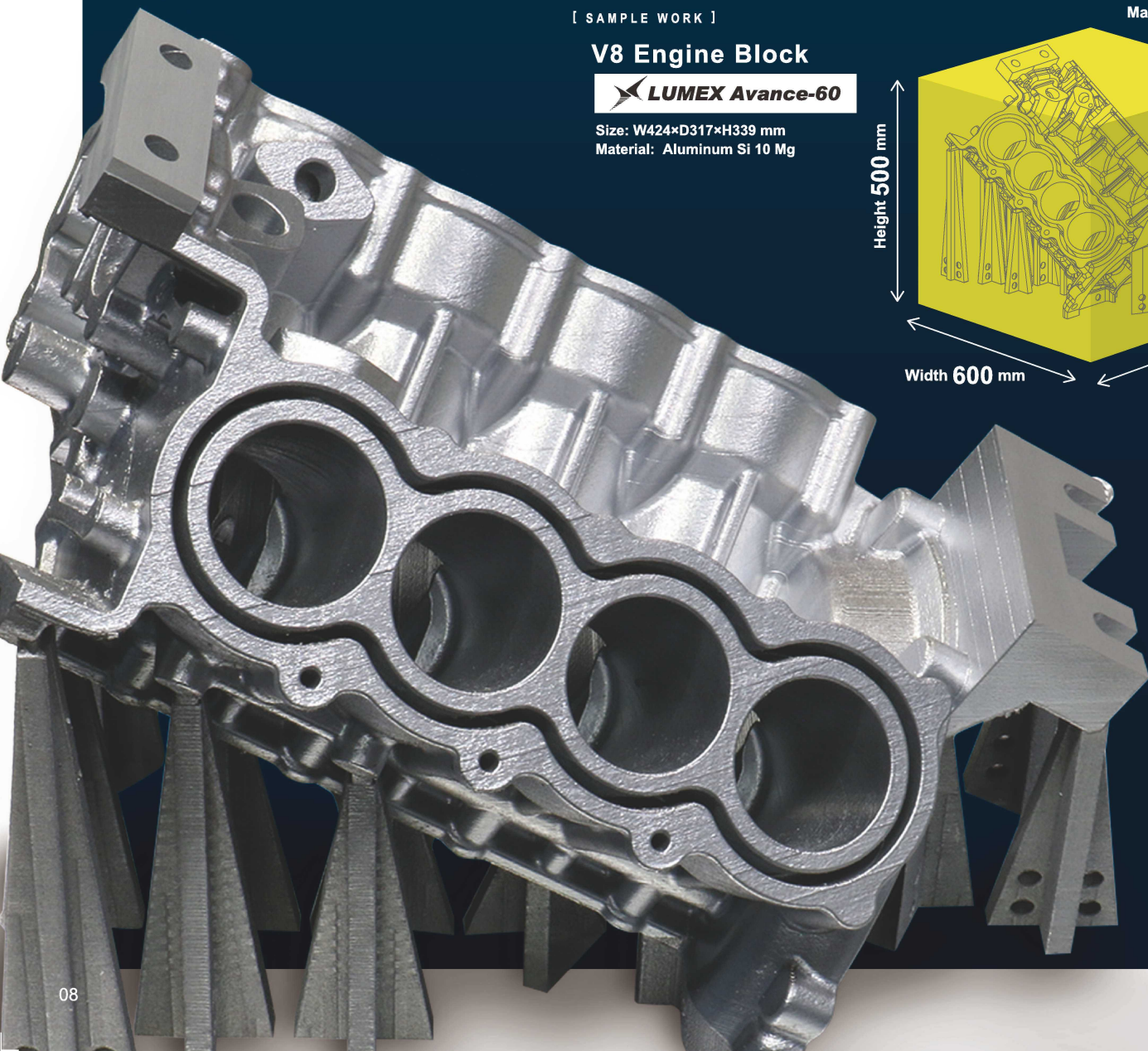
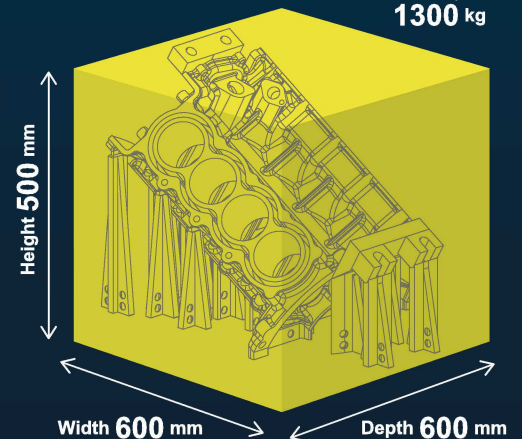



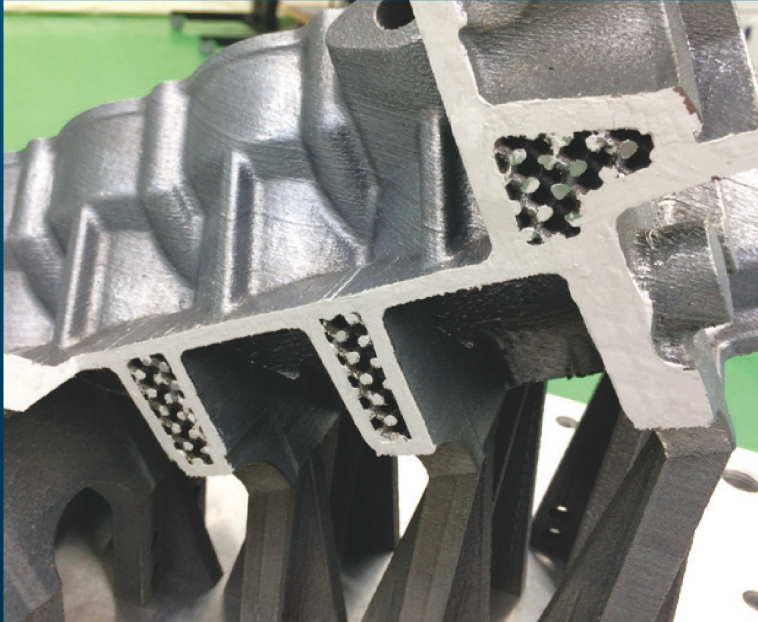

V8 engine block with lattice structure



## High output fiber laser for high speed sintering

- 1 kW fiber laser installed as standard (**LUMEX Avance-60**)
- Enhanced powder distribution speed
- Increased build speed to 35 cc/h \*1
- Milling time reduction by cutting path optimization

\*1: The above is the calculation value, not the guaranteed value.

[ Existing **LUMEX Avance-25** model ]  
(400W - simulation)

Total: 409h 50m  
Sintering: 402h 50m  
Milling: 7h 00m



[ **LUMEX Avance-60** ]  
(1kW)

Total: 95h 00m  
Sintering: 90h 00m  
Milling: 5h 00m

**77% reduction**



## Reference surfaces for subsequent processes can be made

When manufacturing parts that require cutting processes on a machining center, the datum surface and base block necessary for such processes can also be built and machined, which reduces the setup time and costs, thereby shortening the lead time drastically.

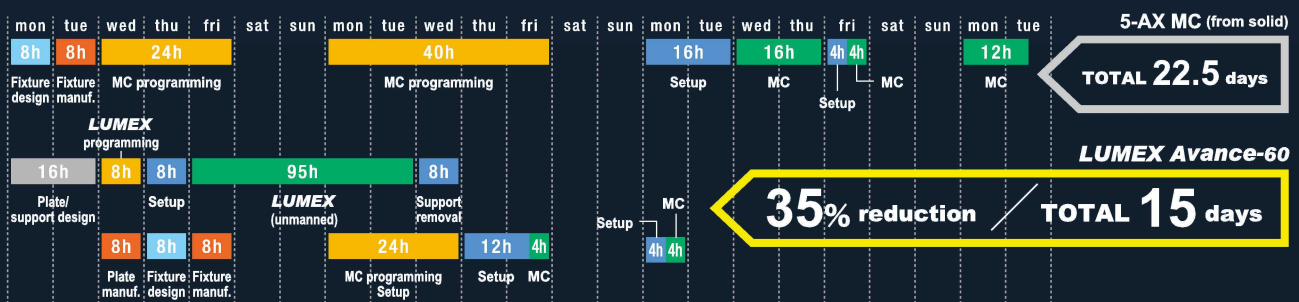
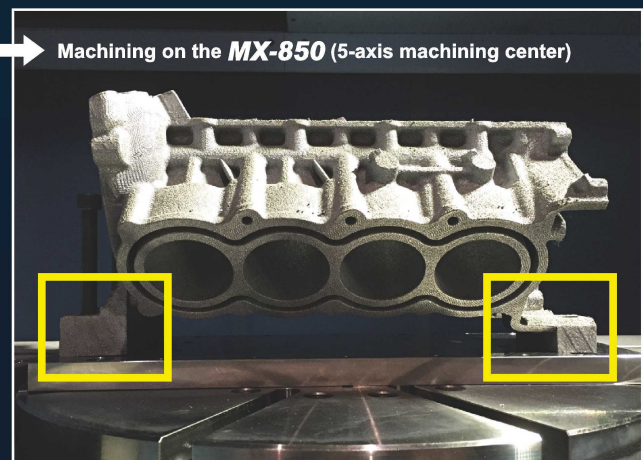
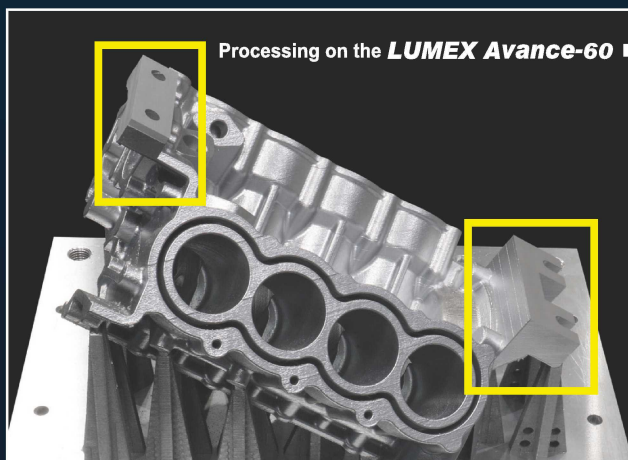

## Aerospace Parts



**Engine jet nozzle**

- **Complicated internal structure**  
Highly functional parts, including aircraft engine parts with complicated internal structures, can be manufactured through free-form sintering with freewheeling thinking not possible with conventional methods.
- **Undercut portions**  
A dedicated tool can be used for roughing to finishing.

[Material] Matsuura Nickel Alloy 718  
 [Cycle time] Sintering: 2 hr 40 min / milling: 13 hr 15 min  
**Total: 15 hr 55 min**

ACCESS HOLLOW

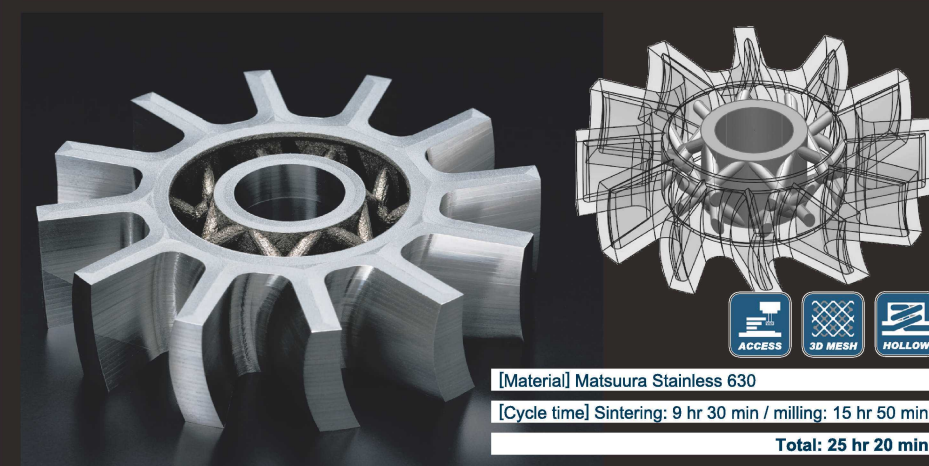

**Blisk**

- **Light weight design**  
Weight-trimming by 44% compared with conventional parts is achieved by designing the disc with a spoke-shaped mesh structure and hollow blades. This design is possible only with additive manufacturing by laser sintering.

[Material] Matsuura Stainless 630  
 [Cycle time] Sintering: 9 hr 30 min / milling: 15 hr 50 min  
**Total: 25 hr 20 min**

ACCESS 3D MESH HOLLOW

## Molds

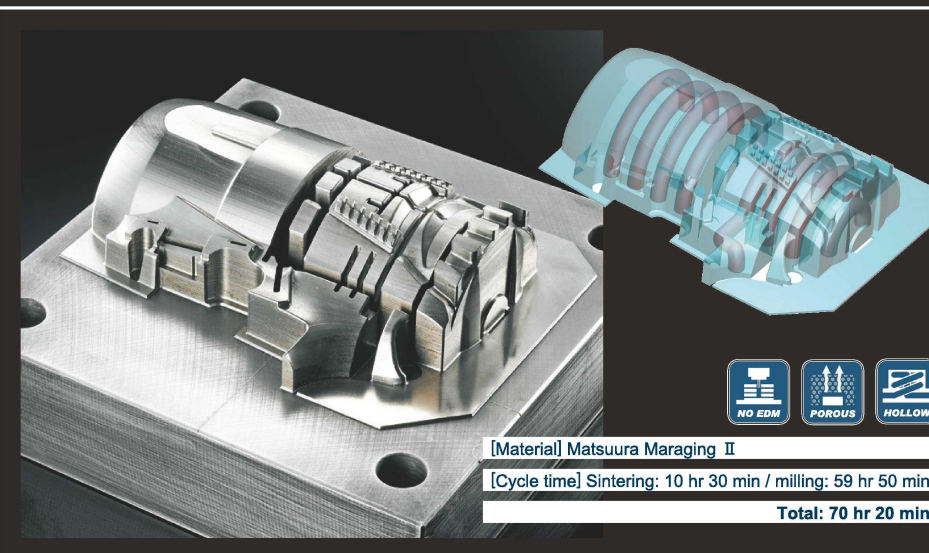

**Electric driver (head)**

- **3D water channels**  

Conventional	Linear water channels
<b>LUMEX Avance-25</b>	3D water channels can be designed along the part surface.
- **Shorter cooling time**  

Conventional (general)	Molding cycle: 53 sec, cooling time: 30 sec
	Solidification within the same cooling time
<b>LUMEX Avance-25</b>	Molding cycle: 43 sec, cooling time: 20 sec
	Molding cycle time: 33% reduction

[Material] Matsuura Maraging II  
 [Cycle time] Sintering: 10 hr 30 min / milling: 59 hr 50 min  
**Total: 70 hr 20 min**

NO EDM POROUS HOLLOW

Laser sintering



Deep rib processing



3D hollow structure



Time shortening



3D free-form surface



Finishing



Milling



Porous sintering



3D meshes



Cost reduction



Integrated structure



Undercut



# Medical Parts

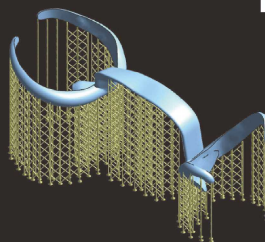
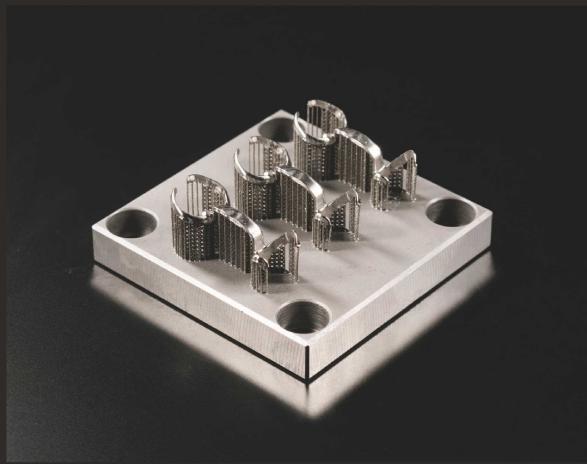

## Dental framework

- Medical parts made of cobalt chrome
- One-off parts in different shapes can be manufactured with ease.
- Finishing of difficult-to-cut materials
- By finishing the portion that requires accuracy with milling tools, the downstream operation time can be shortened.



[Material] Matsuura Cobalt Chrome

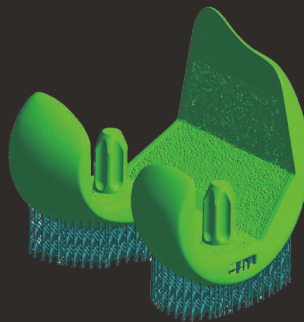
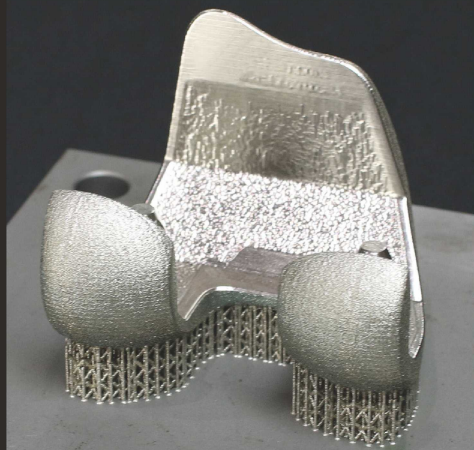

## Knee joint

- Creation of reference surface
- By using the machined surface as a reference surface, it is possible to shorten the set-up time for the next process and minimize the finishing allowance required.
- Automatic support creation
- LUMEX CAM allows the automatic generation of support models.
- The modeled support structures can be removed with an electric multi-tool or hammer and chisel, then the surface finished with by grinding.



[Material] Matsuura Cobalt Chrome

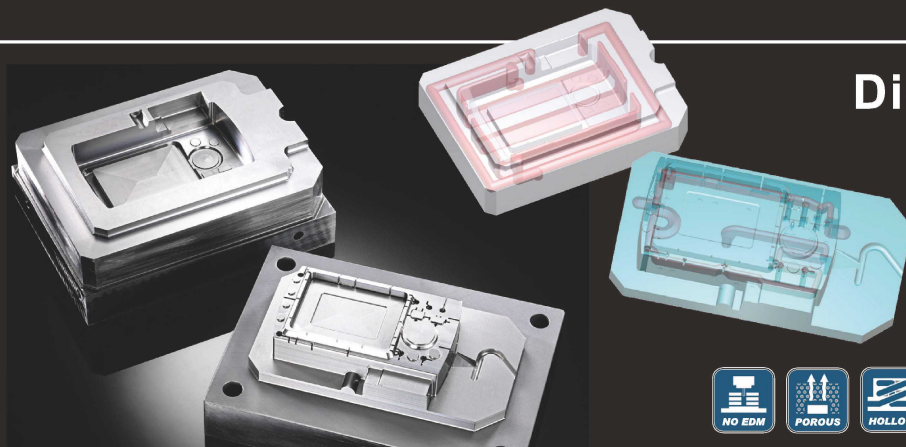

## Digital camera case (cavity and core)

- Sintering time reduction using lattice structure
- Sintering time can be reduced by employing a lattice structure. Hollow sections and surface area increase, making the actual injection molding process efficient.

Cavity part	3D water channels	High speed + lattice structure
Milling time	29h	25h
Sintering time	68h	28h
Total	97h	53h

Cycle time: **45% reduction**

※ Comparison of high speed + lattice structure processing with an existing model

[Material] Matsuura Maraging II

[Cycle time] Cavity part Sintering: 30 hr 45 min / milling: 24 hr 55 min  
**Total: 55 hr 40 min**

Core part Sintering: 14 hr 30 min / milling: 25 hr  
**Total: 39 hr 30 min**

### Standard Machine Specification

	LUMEX Avance-25	LUMEX Avance-60
<b>Traverses</b>		
X-axis travel (Table left/right) [mm]	260	610
Y-axis travel (Table back/forth) [mm]	260	610
Z-axis travel (Table up/down) [mm]	100	100
U-axis travel (Build table) [mm]	185	500
W-axis travel (Powder Distribution Unit) [mm]	522	990
Distance from table to spindle end [mm]	-10 ~ 90	-10 ~ 90
<b>Table</b>		
Build tank size [mm]	270×270	630×630
Max. work weight [kg]	90	130
Build table size [mm]	246×246	600×600
Build table surface configuration	Tap M6(P1) × Pitch 50mm × 24 pcs	Tap M8 × Pitch 50mm × 120 pcs
Max. work size [mm]	W256×D256×H185 (including the base plate)	W600×D600×H500 (including the base plate)
Distance from floor to table surface [mm]	980	1250
<b>Spindle</b>		
Spindle speed [min <sup>-1</sup> ]	450 ~ 45000	450 ~ 45000
Spindle bearing inner diameter [φmm]	25	25
Spindle end	1/10 taper #20	1/10 taper #20
Spindle max. torque [N·m]	1.31	1.31
Spindle airblow	YES	YES
Spindle orientation	YES	YES
<b>Feedrate</b>		
Rapid traverse rate X / Y / Z [mm/min]	60000 / 60000 / 30000	60000 / 60000 / 30000
Rapid feed acc. / dec. X / Y / Z [G]	0.98 / 1.28 / 0.95	0.61 / 0.58 / 0.7
Feedrate X / Y [mm/min]	1 ~ 60000	1 ~ 60000
Z [mm/min]	1 ~ 30000	1 ~ 30000
Feedrate acc. / dec. X / Y / Z [G]	0.77 / 0.73 / 0.66	0.36 / 0.36 / 0.41
<b>Automatic Tool Changer</b>		
Tool shank	Matsuura original #20	Matsuura original #20
Pull stud	Matsuura original #20	Matsuura original #20
Tool storage capacity [pcs]	20	20
Max. tool diameter [φmm]	10	10
Min. tool diameter [φmm]	0.6	0.6
Max. tool length (with condition) [mm]	Specified Tool holder: Matsuura special	Specified Tool holder: Matsuura special
Tool support length of tool holder: α [mm]	α≥3×φ (φ=3,4,6,8,10)	α≥3×φ (φ=3,4,6,8,10)
Max. tool protrusion length from tool holder: β [mm]	β≤5×φ (φ=3,4,6,8)	β≤5×φ (φ=3,4,6,8)
	β≤30 (φ=10)	β≤30 (φ=10)
Max. tool weight [kg]	0.25 (0.55) (incl. holder)	0.25 (0.55) (incl. holder)
	0.05 (0.11) (Tool only)	0.05 (0.11) (Tool only)
Tool change time (Tool to Tool) [sec]	24.4	24.4
Tool change time (Chip to Chip) [sec]	25.4	25.9
Tool selection method	Fixed address	Fixed address
<b>Motors</b>		
Spindle motor [kW]	AC 2.4 / 4.0 (Continuous/ 50%)	AC 2.4 / 4.0 (Continuous/ 50%)
Feed motor		
X-axis [kW]	AC 3.6 / 4.8	AC 4.8 / 6.4
Y-axis [kW]	AC 2.4 / 3.2	AC 3.6 / 4.8
Z-axis [kW]	AC 0.8 / 1.4	AC 0.96 / 1.6
U-axis [kW]	AC 0.75	AC 4.5
W-axis [kW]	AC 0.5	AC 0.5
Tool magazine motor [kW]	AC 0.5	AC 0.5
Material supply motor [kW]	AC 0.03	AC 0.05
Feed axis auto grease supply motor [kW]	AC 0.025	AC 0.025
Oil cooler motor (Spindle, Linear motor) [kW]	AC 0.7	AC 0.7
Chiller motor (Laser system) [kW]	AC 1.18 / 1.54	AC 1.18 / 1.54
<b>Laser</b>		
Laser type	Yb Fiber laser	Yb Fiber laser
Oscillator output range [W]	50 ~ 500	100 ~ 1000
Beam quality (M2)	< 1.1	< 1.1
Wavelength [nm]	1070 ± 5	1070 ± 5
<b>Laser Scanning Module</b>		
Scanning module X / Y	Galvano scanner system	Galvano scanner system
Z	Linear translator	Linear translator
laser wavelength [nm]	1070±5	1070±5
Max. laser power [W]	1000	1000
Power supply voltage [V]	AC 200 / DC 24	AC 200 / DC 24

	LUMEX Avance-25	LUMEX Avance-60
<b>Power Supply</b>		
Electrical power supply [kVA]	28 (Varies with option configuration)	43 (Varies with option configuration)
Power supply voltage [V]	AC 200/220V ± 10% Transformer is required in case voltage is other than above	AC 200/220V ± 10% Transformer is required in case voltage is other than above
Power supply frequency [Hz]	50/60 ± 1	50/60 ± 1
Compressed air supply [MPa]	0.6 ~ 0.93 (Varies with option configuration)	0.6 ~ 0.93(machine side) 0.6 ~ 0.93(APR system side)
Volume of compressed air to be supplied [NL/min]	700 (atmospheric pressure) (Varies with option configuration)	1700 (machine + APR system)
<b>Tank Capacity</b>		
Oil cooler tank capacity (Spindle, Linear motor) [L]	7	7
<b>Machine Size</b>		
Machine height (From floor) [mm]	2050	3000
Floor space (incl. maintenance area) [mm]	3200 W×4800 D (Varies with option configuration)	4700 W×6180 D (Varies with option configuration)
Machine weight [kg]	4500	11000
<b>Accuracy</b>		
Positioning accuracy X / Y / Z [mm]	±0.0025	±0.0025
Repeatability X / Y / Z [mm]	±0.001	±0.001
<b>Machine Capability</b>		
Axial thrust (Continuous/ Max.) X [kN]	1.8/4.5	2.4/6.0
Y [kN]	1.2/3.0	1.8/4.5
Z [kN]	0.2/0.6	0.2/0.6
<b>LUMEX Avance-25 Standard Accessories</b>		
Total safety guard	Door interlock	
Oil temperature controller	Air dryer	
Linear motor cooler	Z-axis balance cylinder	
Nitrogen generator	Interior temperature sensor	
Oxygen densitometer	Fume collector	
Chiller unit	CCD camera & image processing apparatus	
Galvano scanner & Laser controller	Auto tool length measurement detection sensor (Touch type)	
Laser integrated run meter	Spindle integrated run meter	
IPC function	Guide light function	
Qwerty key-arrangement keyboard	15-inch LCD with touch panel	
High table temperature alarm	USB interface 2 ports	
Tools & Tool box	AC 100V Outlet 3 A	
Leveling bolts & Plates	Machine color paint	
Scale feedback X / Y / Z Heidenhain (Absolute)	Pre-milling powder suction	
Feed axis auto grease supply unit		
Pre heating heater & Controller for build table		
3 color signal light (red, yellow, green from top)		
Position from top, red/ alarm, yellow/ work completion, green/ auto run All lights are lighted while laser is oscillating		
* 2 years spindle warranty		

	LUMEX Avance-60 Standard Accessories
Total safety guard	Door interlock
Oil temperature controller	Air dryer
Linear motor cooler	Z-axis balance cylinder
Nitrogen generator	Interior temperature sensor
Oxygen densitometer	Fume collector
Chiller unit	CCD camera & image processing apparatus
Galvano scanner & Laser controller	Auto tool length measurement detection sensor (Touch type)
Laser integrated run meter	Spindle integrated run meter
IPC function	Guide light function
Qwerty key-arrangement keyboard	19-inch LCD with touch panel
High table temperature alarm	USB interface 2 ports
Tools & Tool box	Machine color paint
Pre-milling powder suction	Leveling bolts & Plates
Scale feedback X / Y / Z Heidenhain (Absolute)	
Feed axis auto grease supply unit	
Pre heating heater & Controller for build table	
3 color signal light (red, yellow, green from top)	
Position from top, red/ alarm, yellow/ work completion, green/ auto run All lights are lighted while laser is oscillating	
APR system (Automatic powder recovery system)	
* 2 years spindle warranty	

## Machine Optional Specifications

	LUMEX Avance-25	LUMEX Avance-60
Input command	inch system	inch system
Frequency	50Hz	50Hz
Plate display	English, overseas standard German	English, overseas standard German
Safety standard	CE mark specification China GB standard	CE mark specification China GB standard
Special machine color	Special color (NC box: std) Special color (NC box: same) Special color (NC box: specified separately)	Special color (NC box: std) Special color (NC box: same) Special color (NC box: specified separately)
Spare spindle	Option	Option
Travel	U-axis travel (build table) 300mm	—
Max. Work weight	150 kg (with U-axis travel 300 mm spec.)	—
Power supply voltage	380 V Machine & NC are 200 V. Exterior transformer is required 415 V Machine & NC are 200 V. Exterior transformer is required	380 V Machine & NC are 200 V. Exterior transformer is required 415 V Machine & NC are 200 V. Exterior transformer is required
Powder sieving machine	Aluminum powder specification	—
Laser oscillator	1 kW fiber laser oscillator	500 W fiber laser oscillator Chiller required
Powder vacuum unit	Powder vacuum unit (External vacuum) Automatic powder recovery system	Powder vacuum unit (External vacuum) —
Technical support	1st year maintenance A: Laser inspection Laser inspection & adjustment (twice / year) 1st year maintenance B: Machine software version upgrades Machine software version upgrades 1st year maintenance C: Laser inspection + machine software version update Laser inspection and adjustment (twice a year) + machine software version update	1st year maintenance A: Laser inspection Laser inspection & adjustment (twice / year) 1st year maintenance B: Machine software version upgrades Machine software version upgrades 1st year maintenance C: Laser inspection + machine software version update Laser inspection and adjustment (twice a year) + machine software version update
CAM	Laser & machining program CAM software, LUMEX CAM Laser & machining program Operation instruction	Laser & machining program CAM software, LUMEX CAM Laser & machining program Operation instruction
Tool	Matsura original #20 tool holder Matsura Original endmill for finishing	Matsura original #20 tool holder Matsura Original endmill for finishing
APR system	Automatic powder recovery system	Standard
Table temperature controller	Option	Option
Fume collector	Fume collector for reactive powder	Standard

## Metal Powder Materials

Materials (work)	JIS	LUMEX	
	Equivalent(Component)	Avance-25	Avance-60
Matsura Maraging II	— (18Ni300)	○	○
Matsura Hard Maraging	—	○	—
Matsura Maraging Cobalt Free	—	○	—
Matsura Stainless 630	SUS630	○	—
Matsura Stainless 316L	SUS316L	○	—
Matsura Cobalt Chrome	T7402	○	—
Matsura Nickel Alloy 718	H4553	○	—
Matsura Aluminum Si10Mg	AC4A (AlSi10Mg)	○	○

\* When using aluminum powders, contact Matsura for the information about the conditions of use in advance.

\* Orders in 10 kg units

\* Machine specifications are subject to change without prior notice.

\* Materials other than those specified cannot be used. Please purchase materials from Matsura.

\* There may be additional applicable metal powder materials. Contact Matsura for the latest information.



### Tool magazine

A tool magazine that accommodates 20 milling tools is provided by standard. An automatic measuring device to measure the length of a tool when the tool is mounted to the spindle is also provided. The tool magazine makes it possible to set up tools externally when the chamber is filled with nitrogen, thereby improving work efficiency.

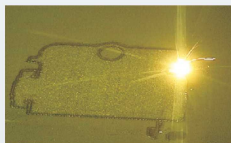

### Yb fiber laser

Yb fiber laser with high beam quality and high efficiency is employed. A small spot diameter can be set to achieve sintering with high power and high resolution. In combination with Matsura's galvanometer mirror, even finer sintering is available. Furthermore, the Yb fiber laser ensures ease of maintenance.



### Oxygen concentration and temperature display

Since metal powder becomes very hot during sintering, the processing chamber is filled with inert gas such as nitrogen. The oxygen concentration and temperature in the chamber is strictly controlled and indicated on the operation panel. If any abnormal condition is detected, the safety function generates an alarm and stops the machine.



### High-speed spindle (45000 min<sup>-1</sup>)

Equipped with Matsura's time-proven high-speed, high-rigidity grease lubricated spindle that rotates at 45000 min<sup>-1</sup> and a 1/10 taper special BT20 tool shank.



### Sintering table

Metal laser sintering is done on this table. The upper surface of the table is heated to alleviate rapid temperature changes resulting from laser sintering, thus increasing the sintering precision.



### CCD camera

A high-precision CCD camera with dedicated software realizes unprecedentedly high-precision laser sintering by incorporating Matsura's visual sensing and feedback technology.



### Linear motor drive

High-precision machining is achieved through high-speed feeding (X/Y: 60 m/min (2.36 ipm) and 30 m/min (1.18 ipm)) by linear drive incorporating Matsura control technology.



### Powder distribution unit

The powder distribution unit is used to spread sintering material (metal powder) on the build table. The operating range of the distribution unit can be specified, thereby achieving speedy and efficient powder distribution.

[ Japanese Patent No. 4351218 ]



### Automatic collection unit

Extra powder on the table is automatically recovered. Operators do not contact with the powder material.

### Automation with an APR system

#### [ Automatic powder recovery system ]

- Fully automated supply, collection and reuse of powder material.
- Maintains a safe working environment to prevent fine powder dispersal.
- Easy and safe material setup is possible with no direct contact with powder.

\* Option for **Avance-25**, standard for **Avance-60**

#### APR System



Powder supply (APR system inside)

- < Powder Supply > Supply the powder material to the build chamber via the suction system.
- < Powder Recovery > Collect the unused powder material after completion of build.
- < Powder Reuse > Collected powder material is automatically filtered by the sieving unit to allow reuse.

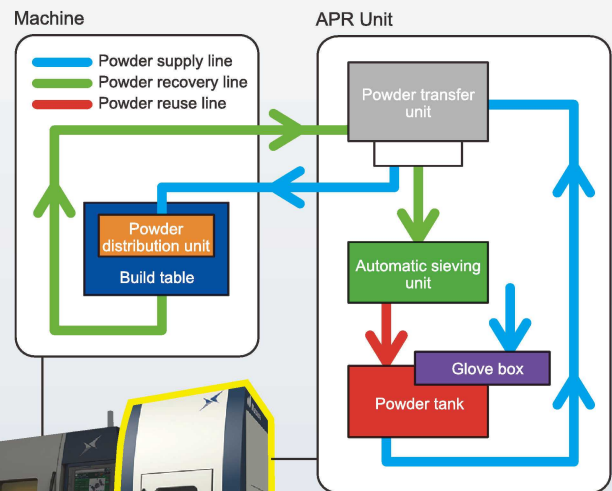

### Safety features for aluminum sintering

For combustible powders, dedicated safety equipment is available to ensure safety.

\* Option for **Avance-25**, standard for **Avance-60**

#### Automatic sieving unit

Ultrasonic sieving is employed. This unit sieves materials efficiently with a low noise level and is less susceptible to mesh clogging. All components have conduction preventive and antistatic effects and inert gas is circulated during operation to prevent powder explosions.

#### Antistatic devices & mats

Antistatic mats are laid in the working area, setup area and maintenance areas. Wrist straps for operators are also provided.

#### Disposable type Fume collector

Fumes are collected powerfully while circulating inert gas inside. By automatically switching between two lines, there is no need to stop the collector when replacing the filter. The airflow monitoring and automatic adjustment functions enable stable laser processing.



※Photo shows **Avance-25**

## LUMEX Avance-25 Standard specifications

[ Floor plan ]

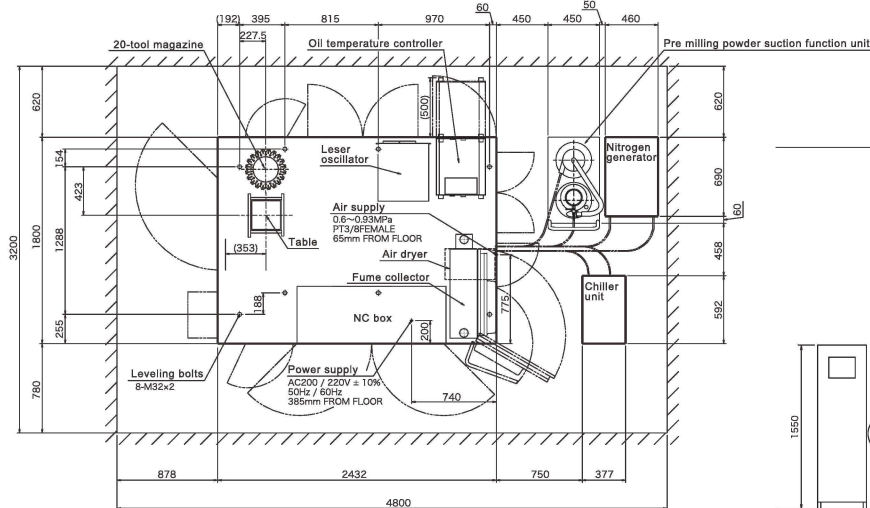

[ External view ]

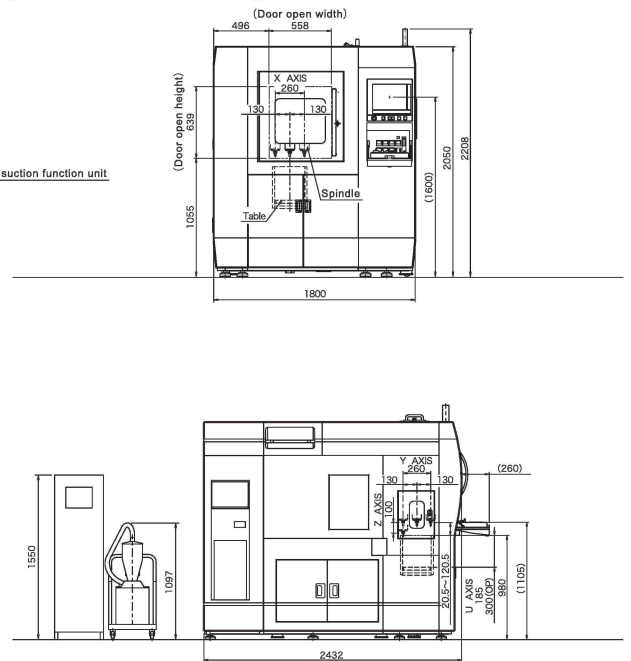

## LUMEX Avance-60 Standard specifications

[ Floor plan ]

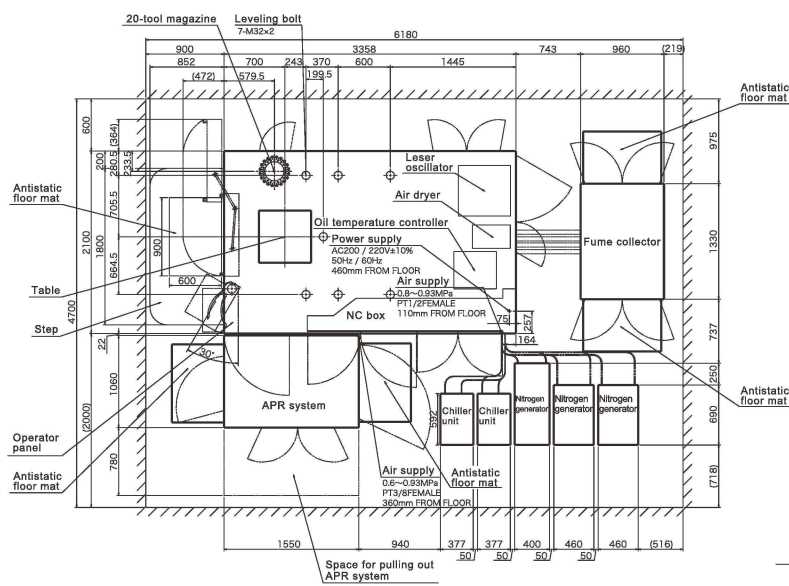

[ External view ]

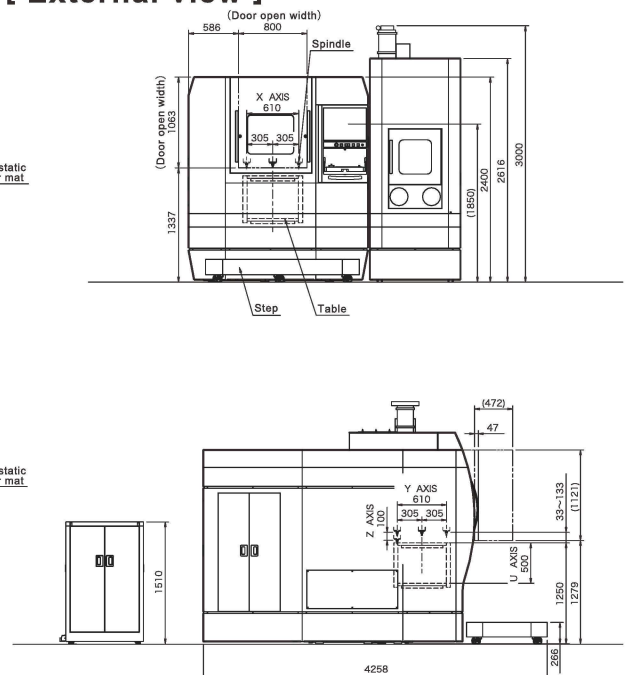



**URL** : <https://www.matsuura.co.jp/>  
**E-MAIL** : [lumex@matsuura.co.jp](mailto:lumex@matsuura.co.jp)

---

**MATSUURA MACHINERY CORPORATION**  
4-201 Higashimorida, Fukui-City 910-8530 Japan  
TEL : +81-776-56-8106 FAX : +81-776-56-8151

---

**MATSUURA EUROPE GmbH**  
Berta-Cramer-Ring 21  
D-65205 Wiesbaden-Delkenheim, Germany  
TEL : +49-6122-7803-80 FAX : +49-6122-7803-33  
URL : <http://www.matsuura.de/>  
E-MAIL : [info@matsuura.de](mailto:info@matsuura.de)

---

**MATSUURA MACHINERY Ltd.**  
Gee Road, Whitwick Business Park, Coalville Leicestershire, LE67  
4NH, England  
TEL : +44-1530-511-400 FAX : +44-1530-511-440  
URL : <http://www.matsuura.co.uk/>  
E-MAIL : [sales@matsuura.co.uk](mailto:sales@matsuura.co.uk)

---

**ELLIOTT MATSUURA CANADA INC.**  
2120 Buckingham Road Oakville Ontario L6H 5X2, Canada  
TEL : +1-905-829-2211 FAX : +1-905-829-5600  
URL : <http://www.elliottmachinery.com/>  
E-MAIL : [sales@elliottmachinery.com](mailto:sales@elliottmachinery.com)

---

**MATSUURA MACHINERY USA INC.**  
325 Randolph Ave., St.Paul, MN 55102, U.S.A.  
TEL : +1-651-289-9700  
URL : <http://www.matsuurausa.com/>  
E-MAIL : [info@matsuurausa.com](mailto:info@matsuurausa.com)

---

- Product specifications and dimensions are subject to change without prior notice.
- The photos may show optional accessories.



This product is subject to all applicable export control laws and regulations